

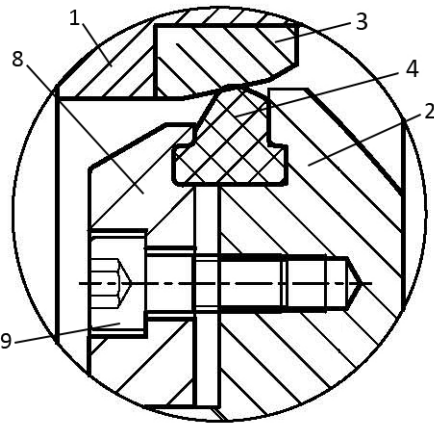

CREAUTZ

BUTTERFLY VALVE, DOUBLE ECCENTRIC, FLANGED, DI BODY, EPDM SEAT (BUTK22-FL)  
ПОВОРОТНЫЙ ЗАТВОР, ФЛАНЦЕВОЕ СОЕДИНЕНИЕ  
КОРПУС ЧУГУН, СЕДЛО EPDM (BUTK22-FL)  
DN100-3000, PN10/16

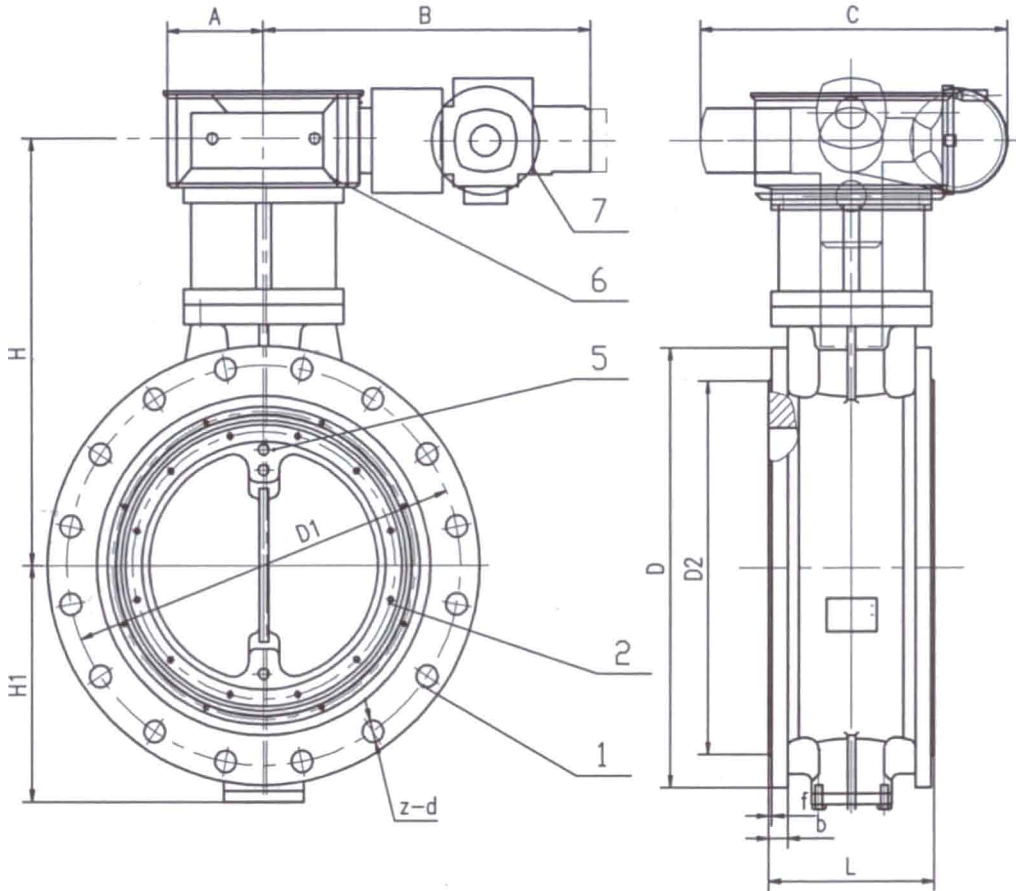

**BILL OF MATERIALS / СПИСОК МАТЕРИАЛОВ**

Но.	designation	часть	Исп. ковкий угун
1	body	корпус	DI / ковкий чугун
2	disc	диск	DI / ковкий чугун
3	body sealing ring	седло	нерж. 304
4	disc sealing ring	уплотнение	EPDM
5	shaft	ось	ASTM A276 410
6	gear	редуктор	
7	electric actuator	эл.привод	
8	retainer ring	прижимное кольцо	steel / сталь
9	bolt	болт	нерж. 304

**BUTTERFLY VALVE, DOUBLE ECCENTRIC, FLANGED, DI BODY, EPDM SEAT (BUTK22-FL)**  
**ПОВОРОТНЫЙ ЗАТВОР, ФЛАНЦЕВОЕ СОЕДИНЕНИЕ**  
**КОРПУС ЧУГУН, СЕДЛО EPDM (BUTK22-FL)**  
**DN100-3000, PN10/16**



**CREAUTZ**

SIZES / РАЗМЕРЫ PN10				PN10	PN16					PN10	PN16		
DN	L	D	D1	D2	b	b	f	H	H1	Z-d	Z-d	Torque, Nm	кг
100	127	220	180	156	19	19	3	300	120	8-19	8-19	85	85
150	140	285	240	211	19	19	3	350	156	8-23	8-23	260	100
200	152	340	295	268	20	20	4	390	210	8-23	12-23	460	115
250	165	395	350	320	22	22	4	410	230	12-23	12-28	685	137
300	178	440	400	368	24.5	24.5	4	440	269	12-23	12-28	1115	150
350	190	505	460	430	24.5	26.5	4	470	295	16-23	16-28	1550	190
400	216	565	515	482	24.5	28	4	500	320	16-28	16-31	2115	272
450	222	615	565	530	25.5	30	4	530	350	20-28	20-31	2794	345
500	229	670	620	585	26.5	31.5	4	565	388	20-28	20-34	3590	501
600	267	780	725	685	30	36	5	727	464	20-31	20-37	5575	635
700	292	895	840	794	32.5	39.5	5	770	513	24-31	24-37	7983	931
800	318	1015	950	901	35	43	5	815	582	24-34	24-40	11105	1132
900	330	1110	1050	1005	37.5	46.5	5	919	638	28-34	28-40	14925	1478
1000	410	1230	1160	1115	40	50	5	978	720	28-37	28-43	19455	1906
1200	470	1465	1380	1330	45	57	5	1250	852	32-40	32-49	32505	2025
1400	530	1675	1590	1530	48	60	5	1370	1003	36-43	36-49	48248	3400
1600	440	1915	1820	1750	49	65	5	1490	1118	40-49	40-56	68246	5300
1800	490	2115	2020	1950	52	70	5	1605	1220	44-49	44-56	93054	7480
2000	540	2325	2230	2150	55	75	6	1900	1435	48-49	48-62	128055	10500
2200	590	2550	2440	2370	60	80	6	2162	1767	52-56	52-62	163195	14875
2400	650	2770	2650	2570	62	85	6	2252	1776	56-56	56-68	205745	20424
2600	700	2960	2850	2780	64	90	6	2397	1955	60-56	60-68	260792	24668
2800	760	3180	3070	3000	66	95	6	2600	2110	64-56	64-68	318182	26780
3000	810	3405	3290	3210	68	100	6	2800	2156	68-62	68-68	383725	28998

	PN10	PN16
Shell test / Испытание корпуса	15 бар	24 бар
Seal test / Испытание уплотн.	11 бар	17,6 бар
Макс. темп. 80°C		
Мин. темп. -20°C		
Фланцы EN1092-2		
Исп. EN12266-1		
Длина DIN3352		
Дизайн BS5155		
Испытание ISO5208		

